



# HOUSING & DEVELOPMENT BOARD

## APPLICATION TO INSTALL CLOTHES DRYING SYSTEM ("THE SYSTEM") AT THE EXTERNAL WALL DESIGNATED FOR CLOTHES DRYING ("THE WORKS")

**Note:** The installation of the System is only for existing flats designed with steel bamboo pipe sockets. It is not to be installed in flats designed with other forms of clothes drying systems or in flats that have undergone or have been scheduled for the Home Improvement Programme (HIP).

### I PARTICULARS OF LESSEE(S)

Names (Mr/Mdm/Ms*)  1. _____  2. _____  3. _____  4. _____	NRIC No.  1. _____  2. _____  3. _____  4. _____	Contact number.  Email address
<u>Address</u>  APT BLK _____ STREET NAME _____ # _____ - _____ SINGAPORE _____		Flat Type

### II NAME OF VENDOR & PRODUCT INFORMATION

Company Name  New Clothes Dryer Pte Ltd	Product Reference number  RKF-C001-2013 01	Contact number  62082964 / 91084216
Company Address  No. 50 Duku Road Singapore 429206		
The vendor hereby undertakes to carry out the Works according to the terms and conditions as set out in the product approval granted by HDB.		
Ong Yew Khoon  Name(s) & Signature(s) of vendor		

### III Terms & Conditions:

I/We, the lessee(s), hereby jointly and severally undertake, agree and covenant that :-

- a. I/We shall ensure that the Works are solely carried out by the above named vendor.
- b. I/We shall be responsible for the proper repair and maintenance of the Works and to ensure that the System is safely secured at all times. I/We shall also be responsible for the rectification of any water seepage to all neighbouring units arising from or in connection with the Works.
- c. I/We acknowledge that, in addition to HDB's approval, I/we have to obtain the approval of the managing Town Council before carrying out the Works.
- d. In the event that the Works pose a danger or possible danger to the public, I/we shall remove the System immediately at my/our own expense.
- e. I/We confirm that the System is purchased from the vendor on the open-market and it is not part of any HDB programme.
- f. I/We agree to be responsible for maintaining the existing bamboo pole holders, if any, in good condition and repair.
- g. I/We acknowledge that the sale, purchase and installation of the System is a contract between the vendor and me/us and any dispute on the pricing, work schedule, type and quality of the Works or the System shall be resolved between me/us and the vendor.
- h. I/We indemnify HDB against all actions, proceedings, suits, claims and demands which may be brought against HDB, and against all monies, costs, expenses, losses and damages which HDB may be liable to pay, incur or sustain in connection with or arising, whether directly or indirectly, from the Works or the System.
- i. In the event that I/we sell the flat, and the flat buyers refuse to undertake to maintain the System, I/we shall reinstate the clothes drying system to its original condition and bear the full cost of reinstatement. Pending the reinstatement of the System, I/we am/are aware that resale will not be completed.
- j. In the event that HDB or the managing Town Council carries out any upgrading or improvement works to the flat, I/we shall remove the System, at my/our own expense, to facilitate the upgrading or improvement works.
- k. I/We acknowledge that HDB reserves the right to issue further instructions on the Works or rescind HDB's approval for the Works. In the event that the System is to be removed, I/we shall do so at my/our own expense within the timeframe stipulated by HDB.
- l. I/We shall work with the vendor to ensure that:
  - (i) precautionary measures are taken during the Works to safeguard the safety of the neighbours and the public;
  - (ii) noisy work (including but not limited to hacking, coring, and using hand-held power tools) shall only be carried out between 9am to 5pm on weekdays, but not on weekends or public holidays;
  - (iii) a minimum of two adjacent neighbouring units are informed of when the Works will be carried out; and
  - (iv) an appropriate barricade accompanied by nylon netting is put in place on the ground floor area directly beneath the flat during the period of the Works.

#### IV UNDERTAKING & CERTIFICATION

1. I/We hereby confirm that I/we have read and agree to abide by the Terms and Conditions stated above.
2. I/We understand that the Terms and Conditions stated above apply to installation works (“the Works”) of the new external clothes drying system (“the System”) carried out on the external wall of a HDB flat and that they complement the technical conditions governing general building work.
3. I/We acknowledge that if any of these terms & conditions are breached, HDB reserves the right to treat the Works as unauthorised. In the event that the Works are unauthorised, HDB reserves the right to require the removal of the System and the reinstatement of the flat to its condition before the Works were carried out, or to a condition set out by HDB, as may be necessary.
4. I/We shall at all times abide by all applicable laws, rules and regulations, and any requirements of HDB, the managing Town Council and/or any relevant authorities, relating to the Works and the System.

\_\_\_\_\_  
Names & Signatures of Lessee

\_\_\_\_\_  
Names & Signatures of Lessee

\_\_\_\_\_  
Names & Signatures of Lessee

\_\_\_\_\_  
Names & Signatures of Lessee

Date \_\_\_\_\_

# Two Way Wall Mounted Aluminium Safety Pipe Socket for Clothes Hanging Pole Suitable For all High-Rise Building (Eco Family Product)

Annex IB

高楼家居安全，环保，内外通用铝合金晒衣竿支撑架

**Patent Application No. 200805123-7**

**Patent No.: 157994**

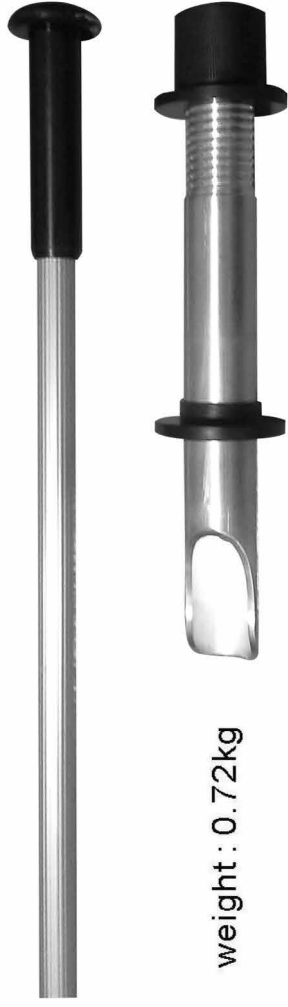

weight : 0.72kg

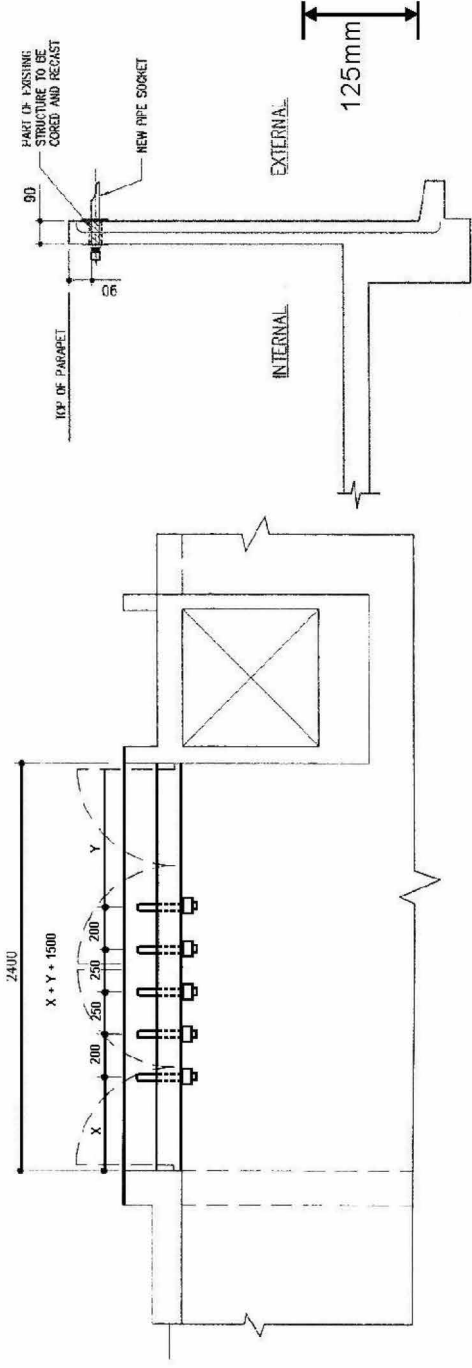
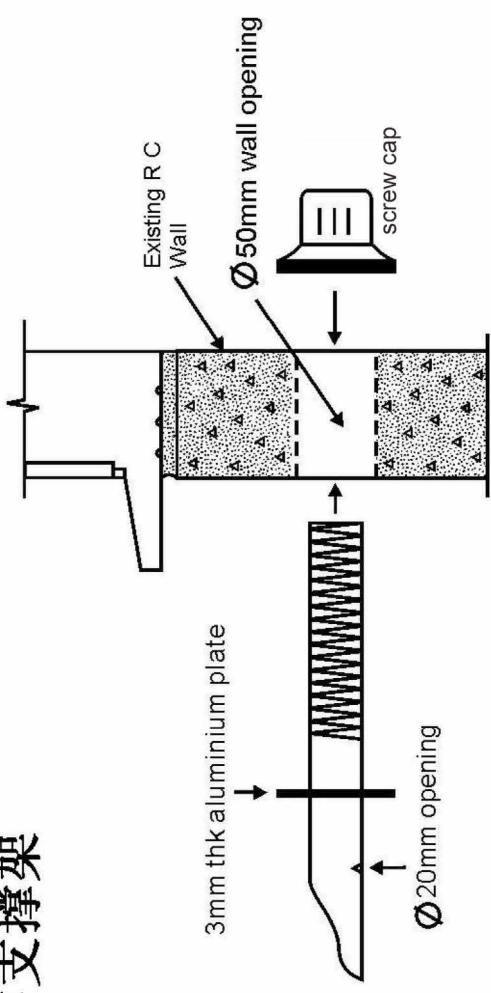

**TYPICAL STOREY FLOOR PLAN OF NEW PIPE SOCKET**

**AT KITCHEN**

SCALE : 1 : 30

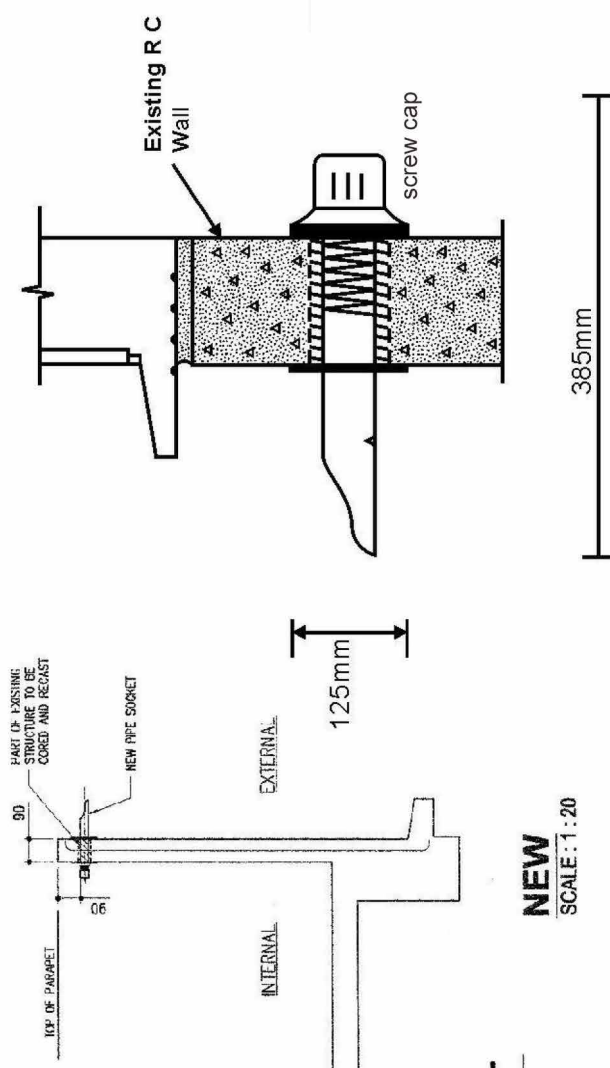

**NEW**  
SCALE : 1 : 20

User Life Protection 家居用户生命的保障